



800 Series

Applications include large rototillers, silage compactors, heavy-duty industrial equipment, material handling.

Features:

- Two-piece aluminum housing for high strength, corrosion resistance and thermal capacity
- Precision machined for exact gear mesh and bearing preload
- Precision forged gears are offered in five ratios: 1:1, 1.18:1, 1.35:1, 1.5:1 and 1.86:1
- Tapered roller bearings provide increased load capacity and bearing life
- 1.75" input shaft and 1.75" output shaft made of high strength steel is standard
- Serviced with 80W90 gear lubricant, run and leak tested before shipment
- The 800 Series weighs approximately 80/90 lbs. including 110 oz of lubricant

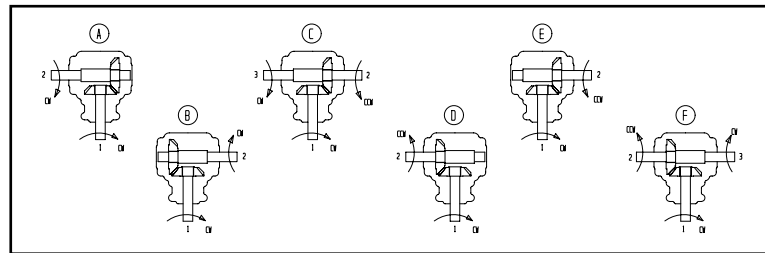
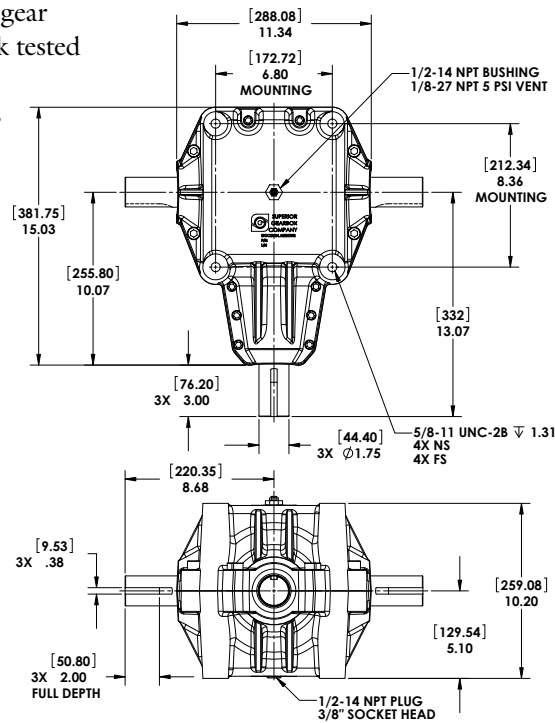
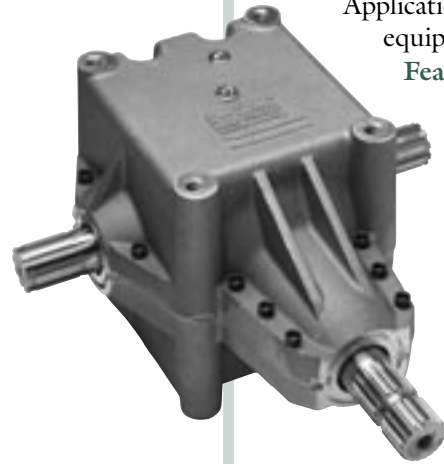

Service Factors												
Character of Shock Driven Machine	Character of Power Source Shock Load											
	Electric Motor Uniform				Multi-Cylinder Engine Light Shock				Single-Cylinder Engine Medium Shock			
	Duration of Service (Hours per Day)											
	.5	3	10	24	.5	3	10	24	.5	3	10	24
Uniform	0.60	0.80	1.00**	1.25	0.80	1.00	1.25	1.50	1.00	1.25	1.50	1.75
Moderate	0.80	1.00	1.25	1.50	1.00	1.25	1.50	1.75	1.25	1.50	1.75	2.00
Heavy	1.25	1.50	1.75	2.00	1.50	1.75	2.00	2.25	1.50	1.75	2.25	2.50

* Divide the horsepower rating by the service factor to obtain the design horsepower. ** AGMA Class 1 Service
 LIMITATIONS ON HORSEPOWER AND TORQUE RATINGS: The horsepower and torque ratings given here are generalizations. Different conditions for various applications may result in higher or lower horsepower capacities. Under certain conditions the maximum indicated rpm may be exceeded. For these reasons the ratings cannot be guaranteed for any application. Prototype testing should be conducted for each application before production.

Rating Chart		Input RPM				
	Ratio ¹	Gear Design	100	540	1000	
Miter	1:1	22T, 22T Forged Straight Bevel	Input HP	47.56	171.29	235.29
			Output Torque*	29975	19992	14829
			Input kW	35.47	127.73	175.46
			Output Torque**	3387	2259	1675
Reducers	1.18:1	28T, 33T Forged Straight Bevel	Input HP	36.62	133.71	184.98
			Output Torque*	27201	18392	13740
			Input kW	27.31	99.71	137.94
			Output Torque**	3073	2078	1552
Reducers	1.35:1	20T, 27T Forged Straight Bevel	Input HP	26.27	102.47	146.32
			Output Torque*	22352	16145	12449
			Input kW	19.59	76.41	109.11
			Output Torque**	2525	1824	1407
Reducers	1.5:1	20T, 30T Forged Straight Bevel	Input HP	19.51	77.85	113.27
			Output Torque*	18444	13629	10708
			Input kW	14.55	58.05	84.47
			Output Torque**	2084	1540	1210
Reducers	1.86:1	14T, 26T Forged Straight Bevel	Input HP	20.45	82.74	121.42
			Output Torque*	23936	17934	14212
			Input kW	15.25	61.70	90.54
			Output Torque**	2704	2026	1606
Increases	1:1.18	33T, 28T Forged Straight Bevel	Input HP	42.26	147.16	198.34
			Output Torque*	22599	14573	10606
			Input kW	31.51	109.74	147.90
			Output Torque**	2553	1646	1198
Increases	1:1.35	27T, 20T Forged Straight Bevel	Input HP	34.40	123.09	168.50
			Output Torque*	16060	10642	7866
			Input kW	25.65	91.79	125.65
			Output Torque**	1814	1202	889
Increases	1:1.5	30T, 20T Forged Straight Bevel	Input HP	28.13	100.66	137.80
			Output Torque*	11819	7832	5790
			Input kW	20.98	75.06	102.76
			Output Torque**	1335	885	654
Increases	1:1.86	26T, 14T Forged Straight Bevel	Input HP	35.65	121.61	162.59
			Output Torque*	12098	7643	5518
			Input kW	26.58	90.69	121.25
			Output Torque**	1367	863	623

¹ All ratings specified with the #1 shaft as the input
 *Torque measured in inch-lbs **Torque measured in N-m

LIMITATIONS ON HORSEPOWER AND TORQUE RATINGS: The horsepower and torque ratings given here are generalizations. Different conditions for various applications may result in higher or lower horsepower capacities. Under certain conditions the maximum indicated rpm may be exceeded. For these reasons the ratings cannot be guaranteed for any application. Prototype testing should be conducted for each application before production.

Contact Superior Gearbox for your special requirements.